

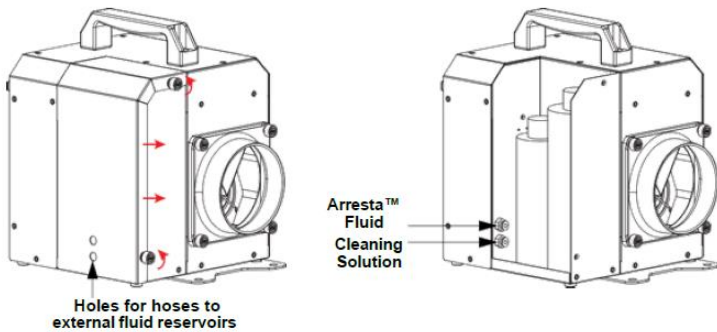

Quick Start Guide

Step 1: Fill the Reservoirs

- Remove the cover via two thumb screws.
- Fill the larger bottle with Arresta and the smaller bottle with the machine cleaner. Place the bottles back in the device and connect tubes to the proper inlets as seen in the diagram below.



Step 2: Turn on the machine.

- Plug in the Clearify™ and flip the red switch ON.
- Let machine warm up, the green display will say “Ready” once unit has reached temperature.

Step 3: Pump Priming

Priming the device will create a cloud of product.

Priming the device should only be done outdoors or in a well-ventilated location.



Priming the Pump using Volume and Fan knobs.

- Make sure you have Arresta™ fluid in the reservoir.
- Turn Fan knob > 50%
- Turn Volume knob to 35%
- Output may pause or sputter as fluid fills the line and the dispersion device
- When hose and machine are full of fluid you will see a steady output of product forming a cloud.
- Once flow is steady, turn the Volume Knob back to Off.
- When output flow has stopped being visible, turn the Fan knob back to Off.

Step 4: Choose configuration (see table below)

- The Clearify™ can be programmed to operate on a defined dispersion cycle by programming in Seconds On and Seconds Off.
- The durations of the on/off cycle determine how much product is in the air.
- Use the table below to match your room size to program settings.

DEVICE	SQ FT	ROOM DIMENSIONS	CEILING HEIGHT	CU FT	DURATION	DEVICE SETTINGS (In seconds)
Clearify	800	20'x40'	10	8,000	2hr	10 on - 60 off at 3% volume
	2,500	50'x50'	10	25,000	2hr	10 on - 30 off at 3% volume
	5,000	71'x70'	10	50,000	2hr	20 on - 30 off at 5% volume
	10,000	100'x100'	10	100,000	2hr	40 on - 30 off at 5% volume

Step 5: Program Configuration

- Once the screen reads “Ready”, press the MENU button 1 time to enter the **Interval Screen**.
- The screen should read Interval and display a number.
 - The Interval is the time between scheduled dispersions, the Off value in the chart above.
 - Use Up and Down Arrow Buttons to set the desired Interval (Off) seconds per the chart above.
- Once the Interval is programmed, press the Menu Button again to move to the **Duration Screen**.
 - The Duration is the amount of time the device will dispense product. This is the “On” value in the chart above.
 - Use Up and Down Arrow Buttons to set the desired Interval (Off) seconds per the chart above.
- Once the Duration is programmed Press Menu button once more to enter the **Output Mode Screen**.
 - The output Options are Volume (continuous output) or Timer (scheduled output).
 - Use the Up Arrow Button to choose “Timer”
 - Press the Enter Button to save your settings.

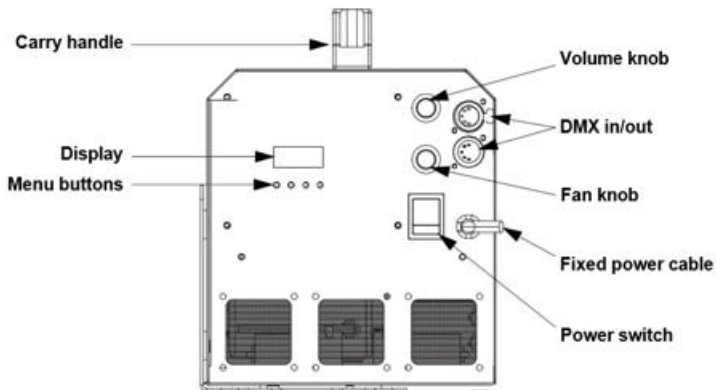

Step 4: Operate Device

The schedule programmed according to the Instructions above will independently operate the device on the fixed Interval/Duration schedule as long

as the device has power, is turned on and has a volume setting.

- Set the fan speed via the Fan Knob.
 - Fan Speed should be set between 50% and 100% during operation.
- Set the Volume Level.
 - Volume Settings are determined via the chart above.
 - Turning the Volume Knob clockwise will increase the output volume.
 - The screen will read “Volume On X%” once the Volume knob is moved off Zero.
- Once the Settings are all in place operate the device via the red On/Off Switch or by turning the Volume knob back to zero to stop dispersion.
- If the red Switch is used to stop dispersion, the pre-set program will run once powered and warmed up.
- Always operate the device on flat hard surface or in its wall mounted configuration.
- Point the Output flange toward the center of the room.
- Leave the room.

Notes:

What Is Not Included

- An external timer, to enable scheduled treatments.
- Recommend using UL listed timers with a 3-prong grounding outlet. Rating: 115V, 60 Hz, 15A/1725W

Instructions For Setting the Timer

- Recommend using UL listed timers with a 3-prong grounding outlet. Rating: 115V, 60 Hz, 15A/1725W
- The external timer is required to schedule treatment cycles. Setting the Clearify™ following the Program Configuration instructions in Step 3 by selecting approximate room size (according to the Dispersion Chart), an external timer will regulate power. The settings will be saved in device memory.

Step 1 – Ensure that there is fluid in the tank and that the tank is properly attached

Step 2 – Take the external timer and plug it into the desired power source (i.e. wall socket)

Step 3 – Plug the Clearify™ or MPU™ device power cord into the external timer.

Step 4 – Turn the device on: for the Clearify™, use the on/off button on the back of the unit; for the MPU™, use the power switch inside the side access panel.

Step 5 – Follow directions for use on the external timer, to set scheduled operating time(s).

Step 6 -- Leave external timer powered on to ensure complete treatment as scheduled.

Cleaning the Device:

Over time the unit may produce a buildup of un-dispersed product in the nozzle or pumps. To address this routine maintenance is recommended. The device should be run thru its cleaning cycle once monthly or at the close of any deployment.

The unit has a small on-board bottle of cleaner in the reservoir compartment. Only use Grignard Machine Cleaner in this procedure.

To run the device's cleaning cycle Press and Hold the Enter Button for 5 seconds.

Running the cleaning process can produce a large cloud of vaporized cleaner. The cleaning cycle should only be run in a large well-ventilated space or outdoors.

Resetting the Fluid Alarm

The unit has an on-board bottle of Arresta™ (larger bottle) in the reservoir compartment. Only use Arresta™ fluid in this machine.

The devices have a low fluid alarm system programmed in. This will warn you via an alarm when the fluid level has reached a re-fill point. Every time a bottle is filled or topped off the counter needs to be reset for the alarm to work properly.

To reset the counter:

- Turn the Volume and Fan knobs off.
- With the machine on “Ready”, hold the “Menu” button down for 5 seconds.

To check the reset

- Turn the Volume and Fan knobs off.
 - Press the Menu Button 8 times to get to the Depleted Screen
 - The Depleted Screen should read “0”.
-

Learn more about how your Clarify X™ device works with Grignard Pure, LLC’s Arresta™ to prevent and eliminate mold and mildew odors.



Grignard Pure, LLC
505 Capobianco Plaza
Rahway, NJ 07065
info@grignardsardpure.com